

J.H.M.C. Robotics, Inc.

HANDLER Regal & Sierra's

10/10/2005

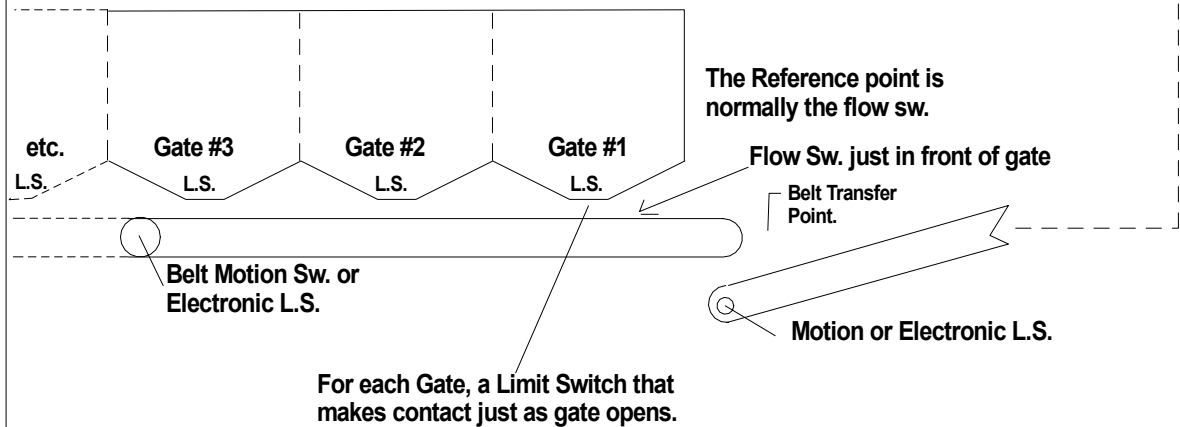

Water spray Bar
anywhere over belt.

Flow switch optional

Over flow sensor
opt. at Turn Head

Turn Head Position L.S.
1 for each Bin position.

Overfill, optional

High Bin indicator

Low Bin indicator
optional

Emergency Low
Bin Indicator
Optional

Plant Bins

This diagram shows a side view of plant bins. A water spray bar is positioned above the belt. A flow switch is optional. An over flow sensor is optional at the turn head. Turn head position limit switches are provided for each bin position. Optional sensors include overfill, high bin indicator, low bin indicator, and emergency low bin indicator.

A Vibrator for all sand gates can be used.

The Belt UNDER the feed Gates must be Belt #1